

BEHAVIOR OF PILES IN LATERALLY SPREADING GROUND DURING EARTHQUAKES

**Scott J. Brandenberg, Priyanshu Singh, Ross W. Boulanger, Bruce L. Kutter
Department of Civil & Environmental Engineering, University of California, Davis, CA.**

INTRODUCTION

Extensive damage to pile-supported bridges and structures in areas of liquefaction and lateral spreading has been observed in many earthquakes around the world. Predicting the behavior of a pile foundation in liquefying ground during an earthquake requires consideration of design motions, free-field site response, superstructure response, and soil-pile-superstructure interaction. Evaluating pile performance requires consideration of the inertial and kinematic loads imposed on the piles and their pile-cap connections, transient or permanent deformations of the pile foundation, the influence of the pile foundation on the dynamic response of the superstructure, and the performance criteria for the pile foundation. The mechanisms involved in soil-pile-structure interaction in liquefying soil are not yet well understood although research in recent years has begun to clarify certain aspects of behavior.

Different mechanisms of damage to pile foundations are illustrated in Figure 1 for level ground conditions and Figure 2 in areas of lateral spreading. The loading conditions include: (1) inertial loading before liquefaction (high shear strain) is triggered, (2) inertial loading plus kinematic loading from ground deformations after liquefaction has been triggered, and (3) kinematic loading from the peak transient or permanent ground deformations. Any one of these load cases may govern the design, and the governing case may be different for the substructure and superstructure.

Simplified design procedures for pile foundations in laterally spreading ground include limit equilibrium methods (e.g., Dobry and Abdoun 2001) and beam on nonlinear Winkler foundation (BNWF) methods. The former approach applies lateral pressures against the pile that are independent of the free-field displacement, which is reasonable when the free-field displacements are large enough for the lateral soil pressures to reach their limiting values. In the latter approach, the free-field site response (e.g., dynamic or permanent deformations) are estimated separately, and then input to the BNWF model as illustrated in Figure 3. Applying this approach to liquefaction problems is complicated by our lack of knowledge of how liquefaction affects the “p-y” behavior of the liquefied soil or an overlying crust (they are usually uncoupled to simplify analyses) and the uncertainty in modeling the free-field response of liquefied deposits. The predictive capabilities and inherent limitations of either analysis method are not yet fully understood, and the resulting uncertainty affects the cost of building new foundations and remediating hazards at existing foundations.

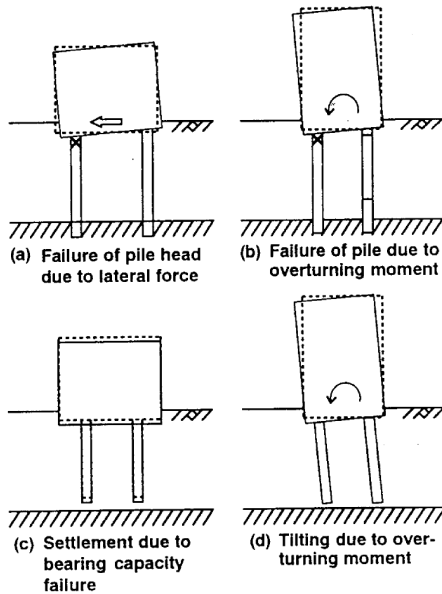

Fig. 1. Schematic of Pile Damage Mechanisms in Level Ground Areas (Tokimatsu et al. 1996)

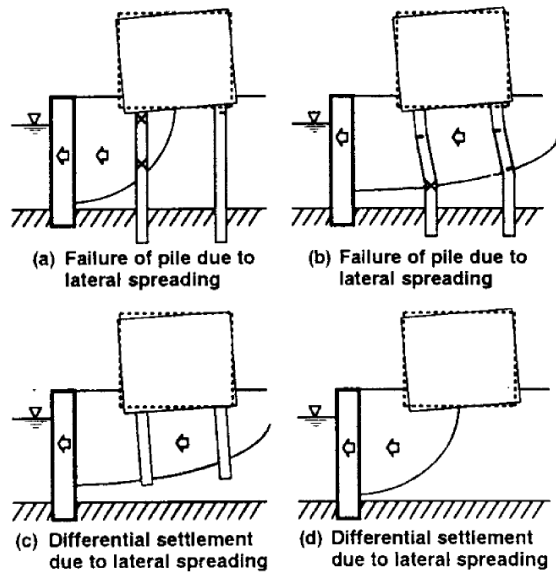

Fig. 2. Schematic of Pile Damage Mechanisms in Laterally Spreading Areas (Tokimatsu et al. 1996)

In the study described herein, a series of dynamic centrifuge model experiments are being performed on the 9-m radius centrifuge at UC Davis to improve our understanding of pile performance in laterally spreading ground and to evaluate emerging design methodologies. Some initial results are presented and the implications for design practice discussed.

LATERAL RESISTANCE OF LIQUEFIED SOIL

The first measurements of dynamic p-y behavior for liquefying sand were presented by Wilson et al. (2000) based on back-analyses of dynamic centrifuge model tests. Results of that Caltrans-supported study showed that the p-y behavior has characteristics that are consistent with the stress-strain response of liquefying sand, as illustrated by the typical p-y loops in Figure 4. The p-y resistance of loose sand (e.g., $D_r \approx 35\%$) was much smaller and softer than for medium-dense sand (e.g., $D_r \approx 55\%$). The ultimate lateral resistance in loose sand ($D_r \approx 35\%$) was generally small when the soil liquefied, even when relative displacements (y) were fairly large. In medium-dense sand ($D_r \approx 55\%$), the p-y behavior progressively softened with time during shaking as pore pressures, strains, and number of load cycles increased. The observed p-y behavior was found to be displacement hardening when relative displacements approached or exceeded past values, especially near the surface. This behavior may be attributed to the nearly undrained loading conditions and the tendency for the soil to dilate under these loading conditions (i.e., large enough strains to move the sand through a phase transformation). Similar observations of p-y behavior have since been reported by Ashford and Rollins (in press, 2001) based on the blast-induced liquefaction testing at Treasure Island and by Tokimatsu et al. (in press, 2001) based on large shaking table tests.

The complex p-y response of liquefying sand is only crudely approximated in simplified design methods. In one of the earliest centrifuge studies of this problem, Dobry et al. (1995) showed that the pile bending moments could be reasonably predicted if the original nonliquefied p-y curves were multiplied by an apparent p-multiplier that decreased more or less linearly with excess pore pressure ratio and reached a minimum value of about 0.1 when the excess pore pressure ratio was unity. Wilson et al. (1999) analyzed the dynamic response of piles in centrifuge tests and concluded that a reasonable p-multiplier for representative peak loading cycles on a single pile in liquefied sand may be about 0.1-0.2 for $D_r \approx 35\%$ and about 0.25-0.35 for $D_r \approx 55\%$. However, the apparent p-y resistance can be expected to progressively soften during shaking as pore pressures increase. It should also be noted that the estimation of inertial and kinematic loads for input to these analyses requires the challenging task of estimating the effects of liquefaction on the dynamic response of the soil profile and soil-pile-structure system. Furthermore, peak bending moments and/or peak superstructure displacements may occur before or after liquefaction develops, and thus both conditions need to be considered.

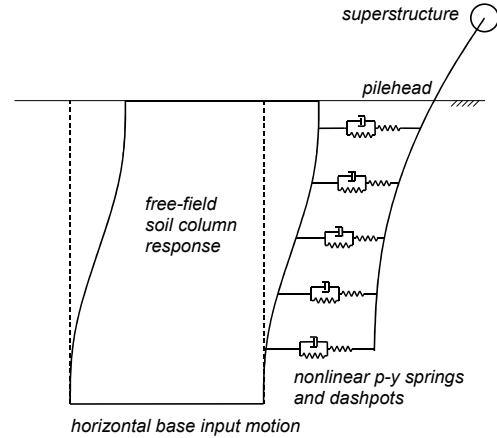

Fig. 3. Schematic of BNWF or “p-y” Model (Wilson et al. 2000)

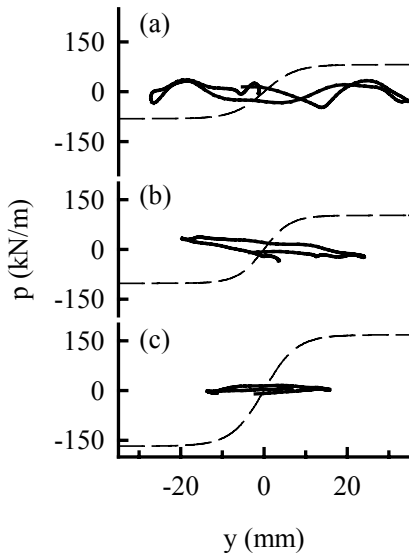

Fig. 4. p-y loops for loose sand ($D_r \approx 35\%$, liquefied) at depths (a) 2-D, (b) 3-D, and (c) 4-D ($D = 0.67$ m). Dashed lines per API (1993). (Wilson et al. 2000)

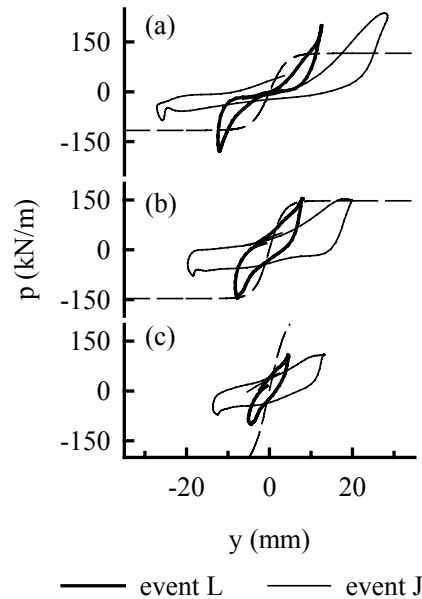

Fig. 5. p-y loops for med. sand ($D_r \approx 55\%$, low r_u in L, moderate r_u in J) at depths (a) 2-D, (b) 3-D, and (c) 4-D ($D = 0.67$ m). Dashed lines per API. (Wilson et al. 2000)

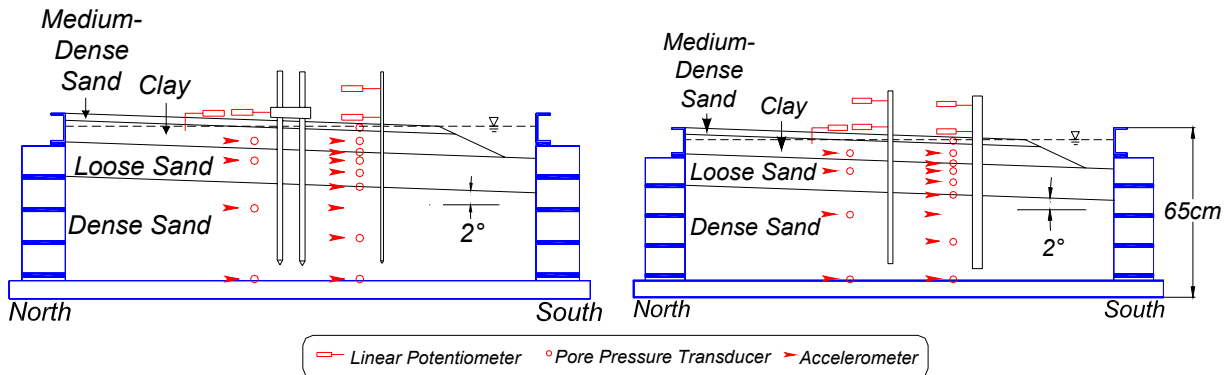

Fig. 6. Cross-sections of first centrifuge model (west side on left, east side on right).

DYNAMIC CENTRIFUGE MODEL TESTS

Centrifuge tests were performed on the 9-m radius centrifuge at UC Davis at a centrifugal acceleration of 38g. Results are presented in prototype units unless otherwise noted. The centrifuge models were comprised of a soil profile that gently sloped toward a channel at one end. The soil profiles had a nonliquefiable crust of clay overlying a layer of loose saturated sand ($D_r \approx 35\%$), overlying dense sand ($D_r \approx 85\%$). The first centrifuge model had single pipe piles with diameters of 0.36 m, 0.73 m, and 1.45 m, and one group of two 0.73-m-diameter pipe piles (with a cap connection for fixed head conditions), located at four separate locations in the model slope. A cross-section of this model is shown in Figure 6. Subsequent centrifuge models have had a group of six pipe piles connected by a large embedded pile cap. Variations between the different centrifuge experiments have included different shear strengths for the clay crust, different earthquake characteristics, and different thickness for the loose sand layer.

Time histories of pile head displacement, ground displacement, and pile bending moments are shown in Figure 7 for the 0.73-m diameter pile and in Figure 8 for the group of two 0.73-m diameter piles from the first centrifuge model test. The model was subjected to three earthquakes, separated by sufficient time to allow full reconsolidation of the soil profile. The time histories from all three earthquakes are shown sequentially in Figures 7 and 8, showing that large residual displacements and pile bending moments remained after the second earthquake. The transient lateral displacements of the clay layer were greater than the residual lateral displacements, and similarly the transient bending moments were greater than the residual bending moments in the piles. The peak bending moments for these piles were not significantly different in the third earthquake than in the second earthquake, despite the further increase in lateral spreading displacement of the nonliquefied crust and an increase in the peak pile displacements. This result indicates that the full passive resistance of the crust had already been mobilized against the piles during the second earthquake.

PSEUDO-STATIC ANALYSIS OF KINEMATIC LOADING

The experimental results were compared against a pseudo-static pushover-type analysis using a beam on nonlinear Winkler foundation (BNWF) approach, as was schematically illustrated in Figure 3. These analyses were performed using the program LPile⁺ (Reese et al. 2000). The free-field soil displacement profiles that were input to the analyses were based on the measured displacement profiles in the centrifuge models. Matlock's (1970) static p-y relation for soft clay

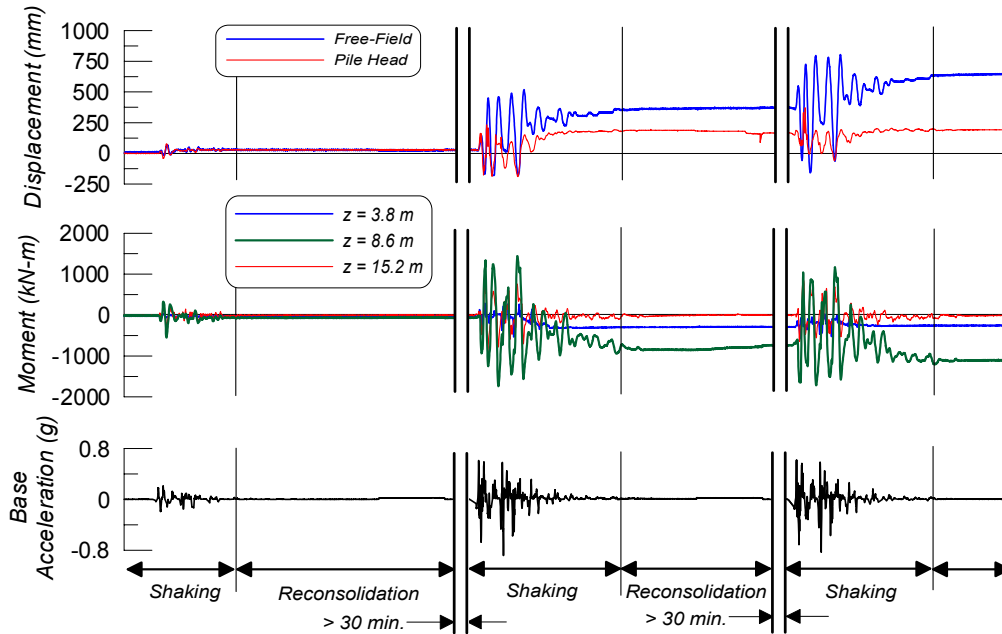

Fig. 7. Displacement, Moment and Base Acceleration Time Histories for the Medium Sized Single Pile. Z is Measured From the Ground Surface.

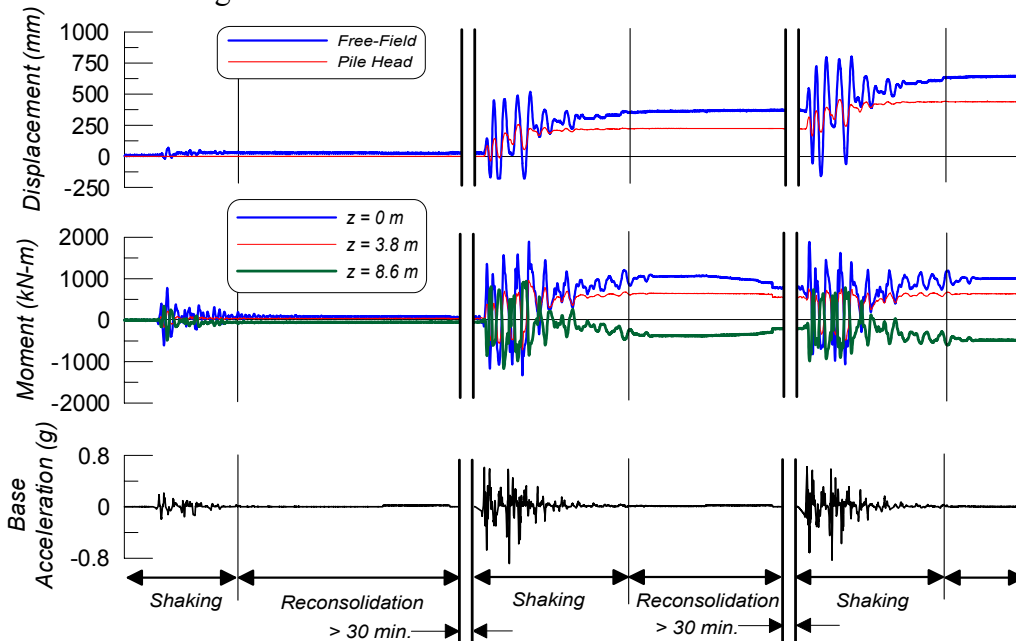

Fig. 8. Displacement, Moment and Base Acceleration Time Histories for the Upslope Pile in the 2-Pile Group. Z is Measured From the Ground Surface.

and Reese et al.'s (1974) static p-y relation for sand were used. A p-multiplier of 0.1 was used for the liquefied loose sand layer. Parameter studies were then used to evaluate the sensitivity of the analysis results to the soil displacement profile, the soil properties, and the p-y relations.

Typical analysis results are shown in Figure 9 for the 0.73-m diameter single pile and in Figure 10 for the two-pile group of 0.73-m diameter piles. In both figures, analysis results are shown for three sets of input parameters [1, 2, & 3] and one soil displacement profile [(b)].

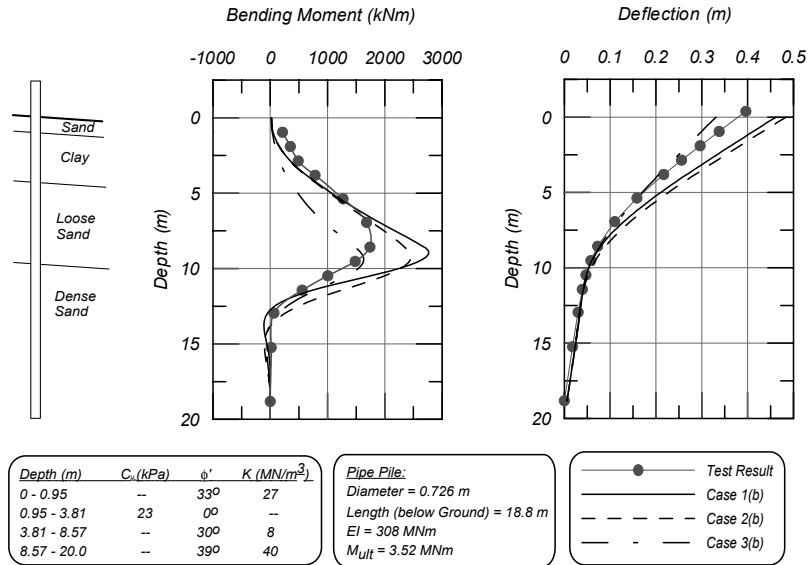

Fig. 9. Calculated and measured responses of the single middle-sized pile.

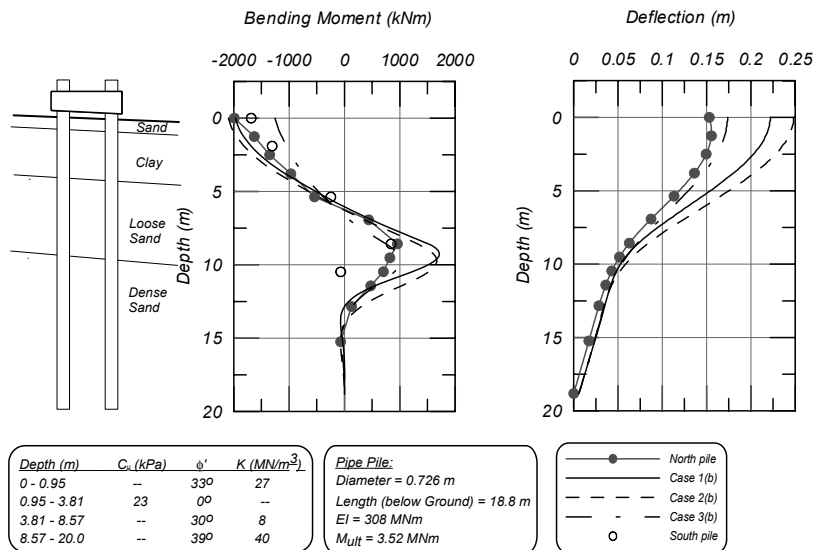

Fig. 10. Calculated and measured responses of the two-pile group of middle-sized piles.

Case 1(b) used the baseline set of p-y relations and soil properties, with only the loose sand layer being softened to account for liquefaction. Case 2(b) included reductions in the p-y stiffness and capacity of the dense sand layer due to pore pressure increases in that layer. Case 3(b) was the same as 2(b) but included the standard p-y adjustment factors for cyclic loading (derived for large numbers of cycles). For the single 0.73-m diameter pile (Figure 9), cases 1(b) and 2(b) over-predicted bending moments by 40-60%, while case 3(b) gave a slight under-prediction of the peak moment but with a poor match to the moment development over depth. For the two-pile group (Figure 10), cases 1(b) and 2(b) gave good predictions of the bending moment at the pile head while over-predicting the bending moment at the bottom of the liquefied layer by about 75%. Case 3(b) under-predicted the bending moment at the pile head by about 40% while being reasonably close for the moment at the bottom of the liquefied layer.

The recorded responses of the three single piles and one group of two piles could be modeled within the range of parameter variations that were studied, but all of the responses could not be accurately modeled with the same set of input parameters. For example, when the baseline set of parameters predicted the peak bending moment of the 1.45-m diameter single pile reasonably well, it over-predicted the peak bending moment in the 0.73-m diameter single pile by about 40-60%. The sources of these discrepancies are being evaluated through further parametric studies.

The parameter studies also showed that the standard adjustments to p-y relations for cyclic loading would have resulted in substantial under-prediction of lateral loads from the clay layer. These cyclic loading factors were derived for large numbers of cyclic loads and are not appropriate for modeling a peak seismic loading condition.

The 0.36-m diameter pipe pile yielded extensively during the test, and while the analyses properly predicted extensive yielding and large displacements, the spread of yielding along this strain-hardening pile was not captured as well.

The calculated bending moments in the piles were more sensitive to the strength and p-y parameters for the upper clay and surface sand cover layers, and less sensitive to the p-multiplier assigned to the liquefied layer. This result is expected for the kinematic loading conditions imposed during these experiments.

CONCLUDING COMMENTS & DESIGN CONSIDERATIONS

This paper described preliminary results from a study of the behavior of pile foundations in laterally spreading ground during earthquakes. Kinematic loading on piles can be a governing load case in the presence of large ground strains, such as in liquefiable soils subject to lateral spreading or soft clays subject to strong shaking. The emphasis of this study has been on obtaining experimental data to better understand the mechanisms of interaction and on evaluating simplified analysis methods for design practice. The results suggest that the use of a BNWF method can provide reasonable estimates of peak deformation and bending moment demands.

When evaluating pile foundations with BNWF analyses, it is not necessarily conservative to assume an overly soft p-y resistance for liquefied or non-liquefied soils. This is true for analyses of either the inertial or kinematic loading components. Instead, it is appropriate to use the best possible estimates of p-y resistance and then allow for appropriate uncertainty in the design process. In this regard, the p-y resistance of liquefying soil may be greater during a peak transient inertial loading than during progressive lateral spreading over numerous loading cycles.

While this study is concerned with lateral spreading loads, it should also be recognized that significant down-drag loads (negative skin friction) can develop on piles, particularly when an overlying nonliquefied layer settles due to re-consolidation of an underlying liquefied layer. Significant down-drag loads were observed in the centrifuge experiments with pile groups.

Lastly, some preliminary finite element (FE) analyses were performed while designing the centrifuge experiments involving the pile groups. These FE analyses were of a pile cap embedded in crust overlying a liquefied layer. These preliminary analyses represented the soils as Von Mises materials, and were limited to large pile groups (such that a plane strain analysis is a reasonable approximation). The results indicate that the stiffness of the load-transfer from the

crust to the substructure can be substantially reduced by the occurrence of liquefaction in the underlying soils. In addition, the FE results suggest that passive force from a nonliquefied crust may be calculated using Rankine theory, whereas log-spiral and Coulomb methods would over estimate the passive force. The passive force was reduced to Rankine levels by the coupling of the crust with the underlying liquefiable layer, which allows failure in the crust to occur far enough away from the substructure that vertical shear on the substructure is minimal. Additional 3D FE analyses and the centrifuge experiments are being used to explore this finding in detail and determine if it can be relied upon in practice.

ACKNOWLEDGMENTS

CALTRANS supported this research project under contract number 59A0162. However, the contents of this paper do not necessarily represent a policy of that agency or endorsement by the State or Federal government. The shaker was designed and constructed with support from the NSF, Obayashi Corporation, and Caltrans. The authors would like to acknowledge the contributions of Dan Wilson and valuable discussions with Abbas Abghari and Angel Perez.

REFERENCES

- Dobry, R., and Abdoun, T. (2001). "Recent studies on seismic centrifuge modeling of liquefaction and its effect on deep foundations." *Proc. 4th Intl. Conf. On Recent Advances in Geotechnical Earthquake Engrg. And Soil Dynamics*, S. Prakash ed., San Diego, CA.
- Dobry, R., Taboada, V., and Liu, L. (1995). "Centrifuge modeling of liquefaction effects during earthquakes." *Proc. 1st Intl. Conf. on Earthquake Geotechnical Engineering*, K. Ishihara, ed., Tokyo, Japan, Vol. 3, pp. 1291-1324.
- Matlock, H. (1970). "Correlations for design of laterally loaded piles in soft clay." *Proceedings, 2nd Annual Offshore Technology Conference*, Houston, Texas, OTC 1204.
- Reese, L. C., Wang, S.T., Isenhower, W. M., Arréllaga, J. A., & Hendrix, J. (2000). *LPILE Plus Version 4.0m*. Ensoft, Inc. Austin, Texas.
- Reese, L. C., Cox, W. R., and Koop, F. D. (1974). "Analysis of laterally loaded piles in sand." *Proc. Offshore Technology Conference*, Houston, Texas, Vol. II, Paper 2080, 473-484.
- Tokimatsu, K., Mizuno, H., and Kakurai, M. (1996). "Building damage associated with geotechnical problems." *Soils and Foundations, Special Issue on Geotechnical Aspects of the January 17 1995 Hyogoken-Nambu Earthquake*, Japanese Geotechnical Society.
- Wilson, D. W., Boulanger, R. W., and Kutter, B. L. (2000). "Seismic lateral resistance of liquefying sand." *J. of Geotechnical & Geoenvironmental Engrg.*, ASCE, 126(10): 898-906.
- Wilson, D. W., Boulanger, R. W., and Kutter, B. L. (1999). "Lateral resistance of piles in liquefying sand." *OTRC '99 Conf. on Analysis, Design, Construction and Testing of Deep Foundations*, J. M. Roesset, ed., Geotechnical Special Publication No. 88, ASCE, 165-179.